

Methane transmitter E2618-CH4 is a member of new PluraSens® family of multifunctional measurement instruments. Applications include underground parkings, boiler houses, kitchens, and other confined spaces, where potentially explosive concentration of methane can accumulate.

The instrument utilises novel fully calibrated and temperature compensated semiconductor metal oxide gas sensor with excellent repeatability, stability and long lifetime.

The transmitter is supplied either in duct-mount or wall-mount version. For the wall-mount version the range of remote probe options is available.

Two analog outputs and RS485 digital interface with industry standard Modbus RTU protocol can be used to connect the transmitter to safety or building automation systems.

Safety requirements

Always adhere to the safety provisions applicable in the country of use.

Do not perform any maintenance operation with the power on. Do not let water or foreign objects inside the device.

Operating conditions

The device should be used in explosion-safe (non ATEX -rated) indoor areas, without aggressive gases in the atmosphere. Allowed conditions are:

- temperature in the range of -40...+85 °C
- relative humidity in the range of 0...100%
- atmospheric pressure in the range of 84...106,7 kPa.

Installation and connection

1. Duct mount version: Assemble the sensor probe and connect it to the device main unit. Make sure that the connections are tightened properly. Cut a 25 mm diameter hole in the air duct at the chosen mounting place. Fix the 25 mm cable gland in the hole. Pass the sensor probe through the gland, adjust it to the appropriate depth and tighten the gland's screw. Unscrew four lid screws and detach the lid from the instrument.

Wall mount version: Unscrew four lid screws and detach the lid from the instrument. Fix the transmitter through mounting holes by screws.

The device should be mounted near the ceiling in proximity to potential methane sources and away from the ventilation holes or dead-air spaces such as corners. Recommended coverage area for each transmitter is 80...120 m² (5...6 m radius).

2. Plug the power cable and connect the analog outputs and/or digital interface terminals to the relevant devices according to the connection diagram.

Make certain that the cable gland is properly tightened to ensure the conformity to IP65 protection class.

The screwless quick connect spring terminals on the E2618 series devices are suitable for a wide range of wires with cross-section 0,2...1,5 mm². The recommended wire stripping length is 8...9 mm. Push the spring loaded terminal lever, insert the wire end into terminal hole and release the lever.

Use twisted pair cable, e.g. LiYY TP 2x2x0,5 mm² or CAT 5, to connect the device to RS485 network. Use one pair for A and B wires and the second pair for common 0 V and power +U wires. to connect the transmitter to Fieldbus network. Respect polarity. Overall length of all connections via RS485 interface should not exceed 1200 m.

3. Place the lid back and tighten it with the four screws.

Dimensions of the E2618 wall-mount version

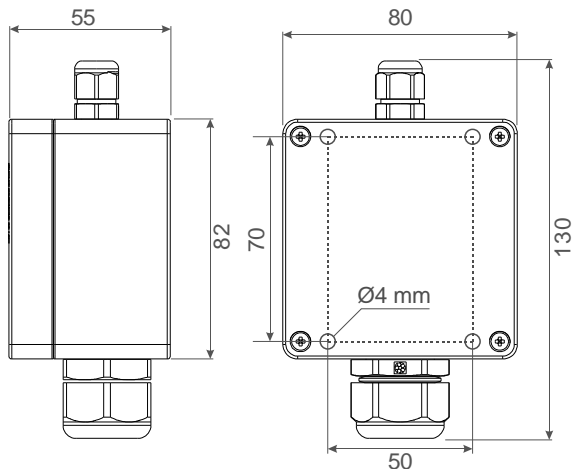

Dimensions of the E2618 duct mount version

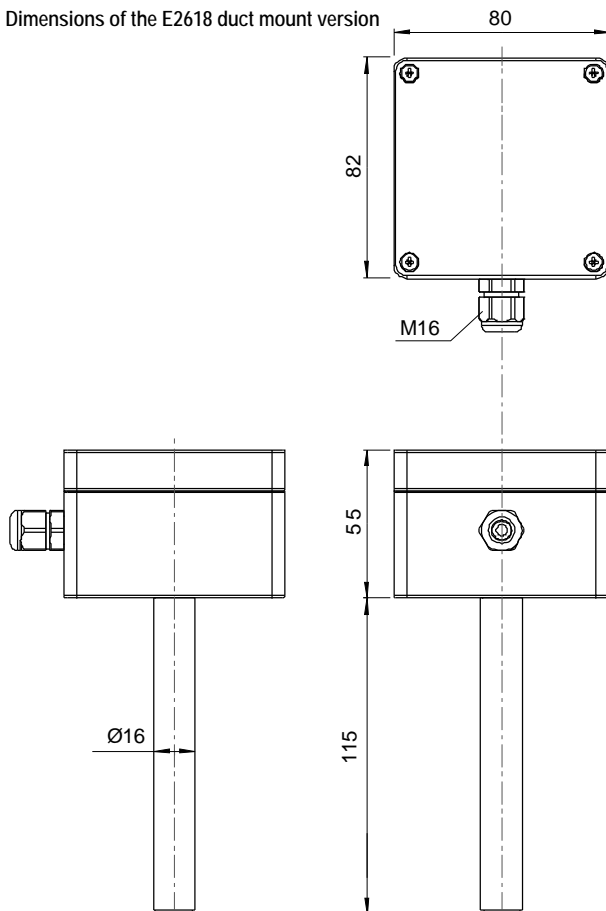

The type of each analog output can be independently changed between 4-20 mA and 0-10 V with jumpers J1 (OUT1) and J2 (OUT2).

With closed jumper the output is 0-10 V, with open jumper the output is 4-20 mA. By default both outputs OUT1 and OUT2 are assigned to gas concentration with the scale 0-100 % LEL (0 -50 000 ppm / 0-5 % vol) of methane CH₄. The device has built-in temperature sensor which may be connected to any of the outputs. The output assignments and scales can be changed by Modbus commands.

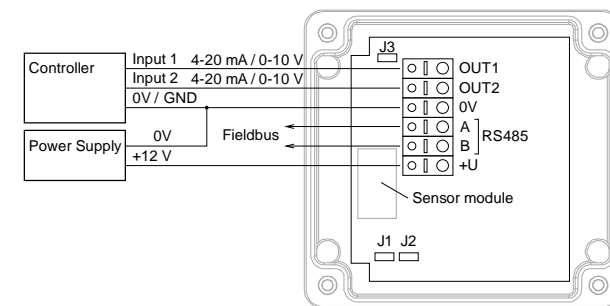

Sensor probe handling

The wall mount version of the transmitter is available with remote probe (see drawing for dimensions).

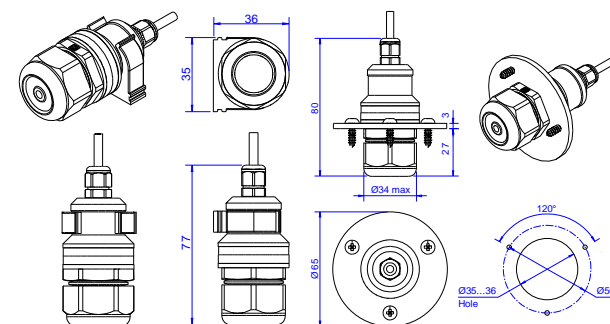

The remote probe is connected to the main unit with shielded cable. The connection cable length options are 3 m, 10 m or 25 m.

The sensor probes of all types are equipped with a hydrophobic microporous PTFE filter to protect the sensor from dust, dirt and water drops. The round filter is snap-fitted and may be replaced if it gets strongly contaminated.

To replace the PTFE filter, carefully hook the filter near its edge with a small flat screwdriver and pull it off. Place a new filter onto the sensor opening and press it to snap into the groove.

NB! Never stab or press the filter near its center where the sensor is located since this may damage the sensor.

The recommended orientation of sensor probe is vertical with the sensor tip pointing downwards. This prevents possible accumulation of condensed water on the sensor protection filter. The horizontal orientation is also suitable. Avoid upward position of the sensor tip.

Sensor heating-up

For best stability the gas detector shall be powered permanently. If the instrument is left for a long time in unpowered state, then after initial power-on the metal-oxide gas sensor needs some time to heat up and burn adsorbed contaminants.

Emergency mode

The current outputs of the transmitter may be programmed via Modbus commands to signal if the connection with the sensor is lost. The signal may be set to 3,8 mA or 21,5 mA. See the table of Modbus registers for more information.

Return to default settings

To reset the device's Slave ID, baudrate and sbit number to factory settings, proceed as follows:

1. De-energize the device
2. Connect the J3 jumper
3. Turn on the device
4. De-energize the device
5. Disconnect the J3 jumper
6. Turn on the device

Calibration

E2618-CH4 has been calibrated by Manufacturer with standard gas mixtures before delivery. The semiconductor gas sensor exhibits high stability and ~10 year lifetime. However, as the gas sensor is directly exposed to environment, the instrument requires at least annual field recalibration with a portable calibration kit. Please contact your distributor for more information.

Delivery set

- Methane transmitter E2618-CH4 or E2618-CH4-DM
- Mounting accessories:
 - 4 screws with plastic dowels for wall mount version
 - 25 mm cable gland for duct mount version.
 - fixing clamp for remote probe versions

Warranty

This product is warranted to be free from defects in material and workmanship for a period of one year from the date of original sale. During this warranty period Manufacturer will, at its option, either repair or replace product that proves to be defective. This warranty is void if the product has been operated in conditions outside ranges specified by Manufacturer or damaged by customer error or negligence or if there has been an unauthorized modification.

General technical data

Sensor type	long-life metal-oxide gas sensor
Detected gase	methane CH ₄
Gas unit	ppm
Sampling method	diffusion
Detection range	0...100% LEL (0 -50 000 ppm / 0-5 % vol)
Resolution	0,1% LEL (50 ppm / 0.005 % vol CH ₄)
Accuracy	± 5 %LEL (250 ppm / 0.25 % vol CH ₄)
Warm-up time	≤ 1 min
Signal update	every 1 second
Response time	~15 seconds
Self-diagnostics	full functionality check at start-up
Power supply	11...30 VDC,
Power consumption	< 2 W
Analog outputs	2 × 4-20 mA / 0-10 V, user settable, freely configurable scales
Digital interface	RS485, Modbus RTU protocol no galvanic isolation, common-mode voltage -7...+12 V,
Cable connections	screwless spring loaded terminals
Enclosure	grey ABS, wall mount, protection class IP65
Dimensions	H82 × W80 × D55 mm
Operating environment	industrial indoor and outdoor locations
Operating conditions	-40...+85 °C, 0...100 %RH
Maintenance interval	12 month
Sensor lifetime	> 10 years
CE marking	according to 2014/30/EU and EN61326-1 requirements

RS485 communication interface

Databits: 8 Parity: none Stop bits: 1 or 2 Protocol: Modbus RTU	Supported Modbus functions: 03 - read multiple registers 06 - write single register
--	---

Communication parameters

Parameter	Permitted values	Default
Supported baudrates	1200, 2400, 4800, 9600, 19200, 38400, 57600	9600
Data bits	8	8
Parity	none	none
Stop bits	1, 2	1
Protocol	Modbus RTU	
Modbus functions	03 - read multiple registers 06 - write single register	
Error codes	01 - illegal function 02 - illegal data address 03 - illegal data value 04 - slave device failure (details of last error 04 can be read from register 0x0008)	



Methane transmitter

E2618-CH4

User manual

E2618 series Modbus holding registers

Register addresses are shown 0-based, Addr in hexadecimal, Reg in decimal format.

Modbus holding register numbers MHR are shown in decimal 1-based format, and may be addressed either from 00001 or 40001 base.

Addr	Reg / MHR	RW	Description	Supported values (dec)	Default
0x0001	1 / 40002	R	Hardware version		-
0x0002	2 / 40003	R	Software version		-
0x0003	3 / 40004	R	Product serial number	1...65535	-
0x0004	4 / 40005	RW	Slave ID (net address) *	1...247 **	1
0x0005	5 / 40006	RW	Baudrate *	1200, 2400, 4800, 9600, 19200, 38400, 57600	9600
0x0006	6 / 40007	RW	Response delay, ms	10...255	10
0x0007	7 / 40008	RW	Stop bits *	1, 2	1
0x0008	8 / 40009	R	Last error code	1...255	-
Restart counter					
0x0011	17 / 40018	RW	Restarts counter	write '42330' to restart device (no response will follow)	-
Sensor type specific parameters					
0x0091	145 / 40146	RW	Heater voltage pulse duration, ms	0...1000 ms	0
0x0092	146 / 40147	RW	Sensor voltage pulse delay, ms	0...995 ms (values 0...4 reserved to set sensor type)	0
0x0093	147 / 40148	RW	Sensor type specific parameter	0...65535	100
0x0094	148 / 40149	RW	Sensor type specific parameter	0...65535	100
0x0095	149 / 40150	RW	Sensor type specific parameter	-32767...+32767	32000
0x0096	150 / 40151	RW	Sensor type specific parameter	-32767...+32767	100
0x0097	151 / 40152	R	Sensor type code	0...65535	0
0x0098	152 / 40153	R	Output units code	0 - ppm, 1 - %, 2 - %	0

* - The new value is applied after restart.

** - Broadcast slave ID 0 can be used to assign a new ID to device with unknown ID. When addressing by ID 0 the device shall be the only Modbus instrument in the network. The device will not respond to Master command when addressed by ID 0.

*** - This value is dynamic and not kept in EEPROM after restart

E2618 series Modbus holding registers (continued)

Register addresses are shown 0-based, Addr in hexadecimal, Reg in decimal format.

Modbus holding register numbers MHR are shown in decimal 1-based format, and may be addressed either from 00001 or 40001 base.

0x00A2	162 / 40163	RW	Zero adjustment for temperature	-32000...+32000 (-320,00...+320,00 °C)	0
0x00A5	165 / 40166	RW	Zero adjustment for gas data, ADC	-32000...+32000 ADC units	0
0x00A6	166 / 40167	RW	Slope adjustment for gas data	1...65535	512
0x00A7	167 / 40168	RW	Change rate limit for gas data,	1...32000, 0 - no limit	0
0x00A8	168 / 40169	RW	Integrating filter time constant, s	1...32000 (seconds), 0 - no filter	0
0x00C9	201 / 40202	RW	Parameter tied to analog output 1	0-none 1- temperature 2- gas concentration 9- forced Modbus control, value set in MHR / 40204	2
0x00CA	202 / 40203	RW	Parameter tied to analog output 2	0-none 1- temperature 2- gas concentration 9- forced Modbus control, value set in MHR / 40205	2
0x00CB	203 / 40204	RW	Forced value for analog output 1***	0...1000 (0,0%...100,0% of output scale)	0
0x00CC	204 / 40205	RW	Forced value for analog output 2***	0...1000 (0,0%...100,0% of output scale)	0
0x00FF	255 / 40256	RW	Sensor and analog outputs status	bit[0]=0/1 - sensor present/absent, read-only! bit[1]=0/1 - analog outputs deactivated/activated, bit[2]= 0/1 - in case of sensor absent, turn signaling off/on analog output1, bit[3]=0/1 - in case of sensor absent, turn on signaling with low current/high current on analog output1; if bit[2]=0 this bit will be ignored, bit[4]=0/1 - in case of sensor absent, turn signaling off/on analog output2 bit[5]=0/1 - in case of sensor absent, turn on signaling with low current/high current on analog output2; if bit[4]=0 this bit will be ignored, bit[6]=0/1 - current/voltage output detected on output1, read-only! bit[7]=0/1 - current/voltage output detected on output2, read-only! bit[8]=0/1 - LED deactivated/activated, bit[9]=0/1 - buzzer deactivated/activated, Note bits [8] and [9] are always 0 for E2618 series	62d
0x0100	256 / 40257	R	Raw temperature data, °C×100	signed integer, -4000...+8500 (-40,00...+85,00 °C)	-
0x0101	257 / 40258	R	Raw gas sensor data	ADC data 0...4095	-
0x0102	258 / 40259	R	Measured temperature, °C×100	signed integer, -4000...+12500 (-40,00...+125,00 °C)	-
0x0103	259 / 40260	R	Gas concentration, ppm / ‰	signed integer, -32000...+32000 (ppm / ‰)	-
0x0105	261 / 40262	RW	0% value for analog output 1	signed integer, -32000...+32000 (ppm / ‰)	0
0x0106	262 / 40263	RW	100% value for analog output 1	signed integer, -32000...+32000 (ppm / ‰)	1000
0x0107	263 / 40264	RW	0% value for analog output 2	signed integer, -32000...+32000 (ppm / ‰)	0
0x0108	264 / 40265	RW	100% value for analog output 2	signed integer, -32000...+32000 (ppm / ‰)	1000

* - The new value is applied after restart.

** - Broadcast slave ID 0 can be used to assign a new ID to device with unknown ID. When addressing by ID 0 the device shall be the only Modbus instrument in the network. The device will not respond to Master command when addressed by ID 0.

*** - This value is dynamic and not kept in EEPROM after restart